

Bōab[™] FT80

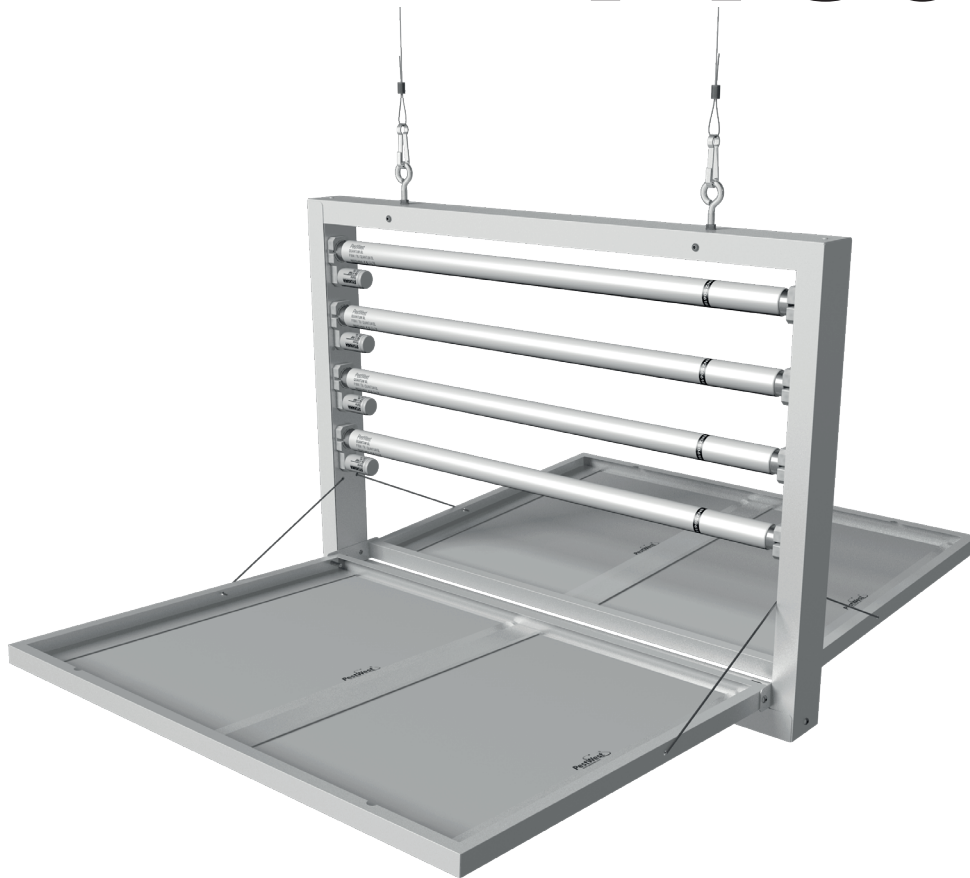

INSTRUCTIONS FOR USE |

| HƯỚNG DẪN SỬ DỤNG |
| PETUNJUK PENGGUNAAN

PRECAUTIONS



We recommend that PestWest QBL UV-A fluorescent shatter-resistant lamps should always be used in our units that are installed in food facilities.

- **Switch off the machine before servicing or cleaning.**
- **Keep out of reach of children.**
- **Ensure the unit is properly earthed.**
- **If the supply cord is damaged, it must be replaced by the manufacturer, its service agent or similarly qualified persons to avoid a hazard.**
- **Ensure that operators have adequate and secure working platform, when working on the machines.**
- **To maintain the attractive appearance of the units, wipe down and clean as often as required. Use a cloth dampened with water and detergent or a proprietary cleaner. Do not use scouring pads or abrasives.**
- **A Risk Assessment for non-target species should be made prior to installation**

SAFETY & OPERATING INSTRUCTIONS

This appliance is not intended for use by persons (including children) with reduced physical, sensory or mental capabilities, or lack of experience and knowledge, unless they have been given supervision or instructions concerning use of the appliance by a person responsible for their safety.

Children should be supervised to ensure that they don't play with the appliance.

This appliance is to be kept out of reach of children

Do not replace any electrical cords yourself. You must use a registered electrical contractor.

The unit can be hard wired, but you must use a registered electrical contractor.

An additional advantage is as security lighting for your premises. Operational costs are minimal by comparison to most other electrical appliances.

UNPACKING YOUR UNIT

Each unit is carefully inspected and packed before leaving our factory. Before discarding the outer carton, examine for obvious evidence of transport damage. Remove the unit and pay particular attention to the removal of all packing materials before installing the unit.

SITING

The efficiency of the unit can be affected by the intensity of other light sources, e.g.: daylight. Therefore, the unit should be mounted where competition from other light sources is minimised.

In food areas, mount the unit close to, but not directly over, exposed food or preparation surfaces (preferably to attract flies away from sensitive areas rather than towards them).

Observe where the flies tend to congregate and if possible, put your flytrap in or close to that area.

Site the units near where flies are likely to gain access, e.g.: doors and windows opening to the outside, especially dustbin areas.

Position the trap where it can be easily reached and not over working machinery where access may be difficult or dangerous.

INSTALLATION

The FT80 is a strong, commercially designed unit which can be easily fitted to wall (single side open) or ceiling (both flaps open).

This unit can be either wall mounted or suspended:

Wall Mounted

1. Undo the 2 screws (power cable side) to remove plug and power cable.
2. Replace the 2 screws, this will lock the panel back in place ready for wall mounting.
3. Drill holes in wall ready for screws. Fix firmly against wall using suitable size screws.
4. Remove the 2 other screws on the other panel to allow the panel to open.
5. Four wing support rods hold the panel at approximately 45 degrees.
6. Remove sticky pad cover and place the sticky paper in the long clips in panel. This will assist to hold the sticky paper in place.

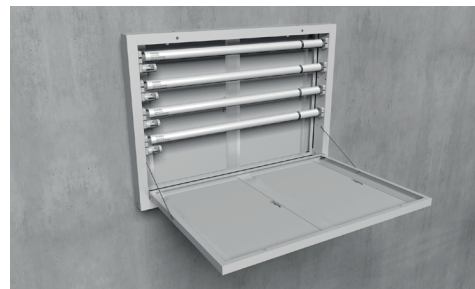

Ceiling Mounted

1. Remove 4 screws to allow both sticky pads to open and then fit rods.
2. Hold trays at approximately 45 degrees.
3. Remove sticky pad cover sheet.
4. Place 2 sticky pads (one in each tray).

Metal 'captive' glue pad trays hold pads in vertical or horizontal position.

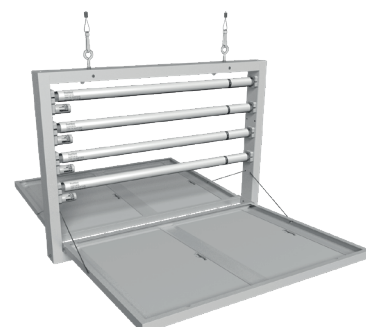

MAINTENANCE AND CLEANING INSTRUCTIONS

- You must switch off power & unplug unit before cleaning commences.
- Take out light tubes and remove glue board.
- Remove any dust or dirt with cloth or duster.
- Clean approx. once every 3 to 6 months, depending on use.
- We suggest the unit be kept on 24 hours a day 365 days a year, as some insects are about all year round.

REPLACING TUBES & GLUE BOARDS

You must switch off power & unplug unit before replacing any part.

The sticky board will normally retain their stickiness for at least 4 weeks. However, if there is a high level of trapped insects or high dust levels you will need to replace the glue boards much earlier. Glue Pad Part No. is: **SKP Yellow -10 pk.**

Replace old glue pad with new one. Hold at one corner and pull away protective cover. Sticky side facing upwards.

18W Tubes & Starters (S2) should be changed approximately once every 10-12 months to maximum effectiveness.

VOLTAGE RANGE	220-240V
FREQUENCY RANGE	50-60 HZ
POWER CONSUMPTION (@230V 50Hz)	85W
CLASSIFICATION	CLASS 1
AMBIENT OPERATING TEMPERATURES	0 TO +40 °C
LED DRIVER TYPE	MAGNETIC BALLAST
AREA OF COVERAGE	SINGLE SIDED 200m ² DOUBLE SIDED 400m ²
REPLACEMENT TUBES (4 QTY)	130-000174 – 18W TUBE 60CM
MOUNTING METHOD	SUSPENDED - SINGLE / DOUBLE SIDED
UNIT DIMENSIONS (CM)	W:10 X H:67 X D:50
WEIGHT	8.5KG

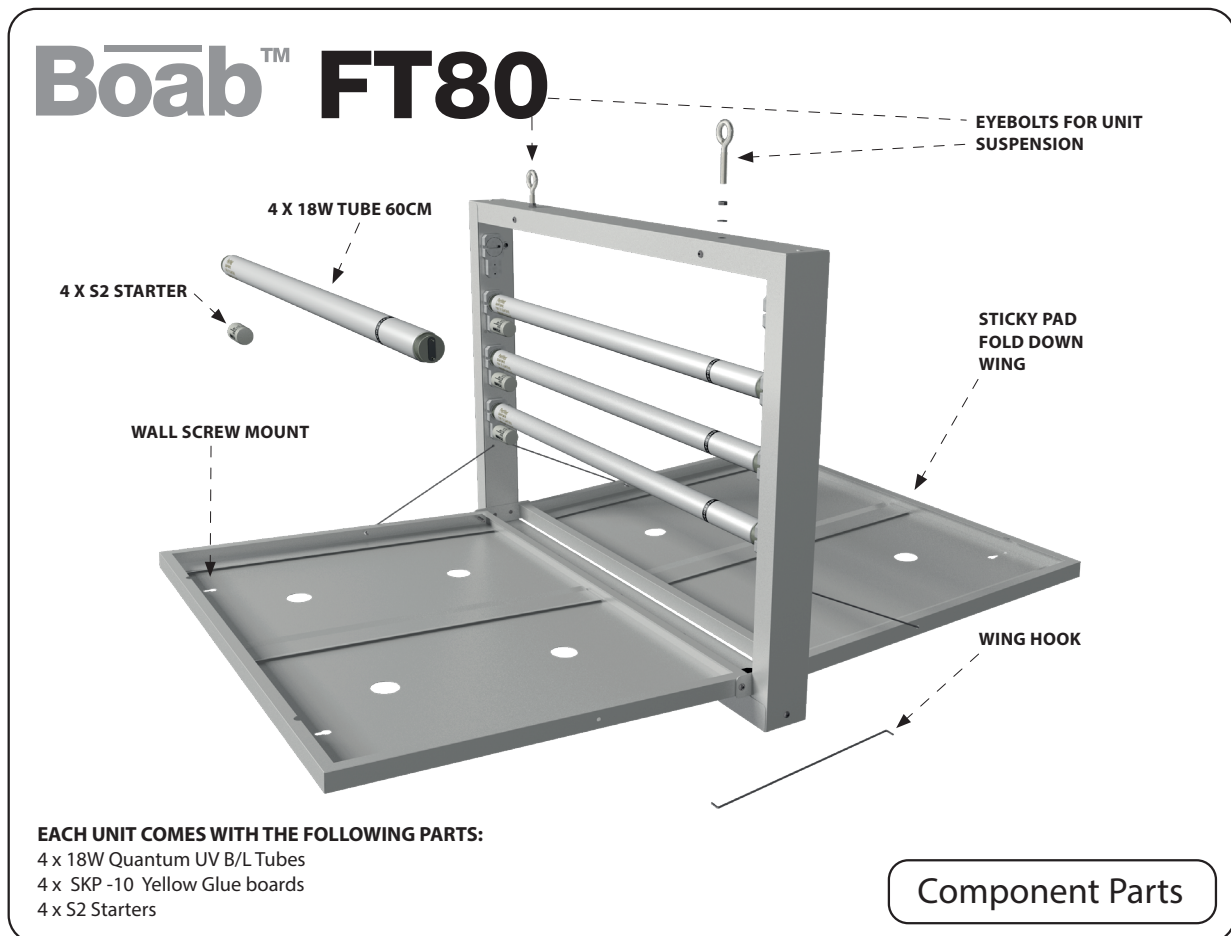

WE RECOMMEND THAT YOU ONLY USE GENUINE REPLACEMENTS FROM PESTWEST.

NON- GENUINE PARTS DO NOT MEET THE SAME HIGH STANDARDS AND MAY VOID YOUR WARRANTY.

GUARANTEE

All PestWest traps are guaranteed for 3 years (excluding LED tubes and sticky boards).

Manufacturer reserves the right to vary model specifications without notice.

Boab[™] FT60

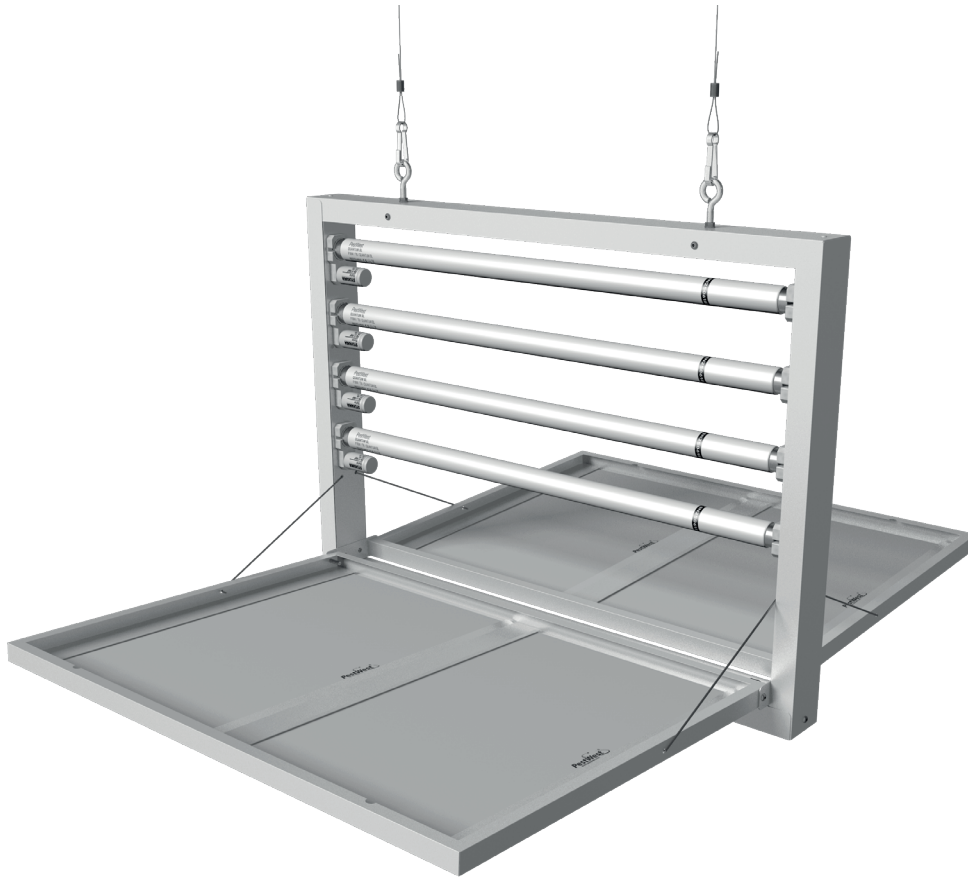

PestWest Electronics Ltd operates a quality management system certified to ISO 9001

PestWest[®] Australia
4 Tesla Link, Wangara, Perth ,W.A 6065
Office: +61 (8) 9302 2088
email: info@pestwest.com.au

www.pestwest.com

Confidence in
Fly Control